

Connecticut Precast Corp.

Manufacturers of Concrete Products

555 Fan Hill Road, Monroe, CT 06468
Telephone (203) 268-8688 Fax (203) 452-1007

www.ctprecast.com

Manholes 48"[1219] Diameter

PRECAST CONCRETE
W/DOGHOUSE BASE SLAB
FLAT TOP CONSTRUCTION

Manholes
CTDOT

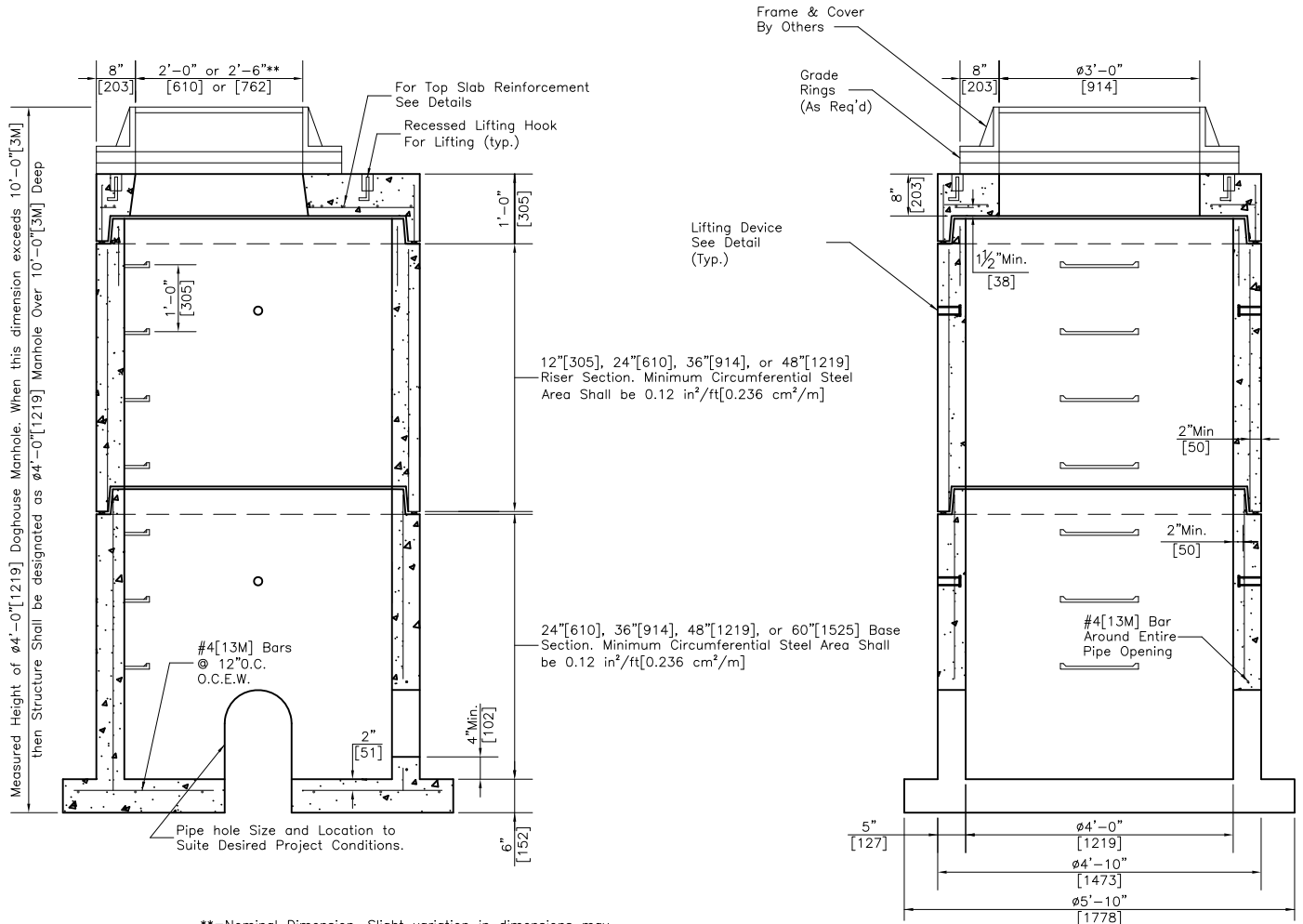
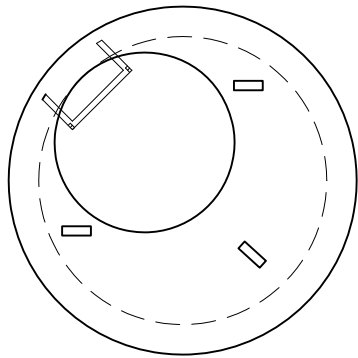

***=Nominal Dimension. Slight variation in dimensions may occur due to tapering for manufacturing purposes.

PRECAST CONCRETE 48"[1219] DIAMETER

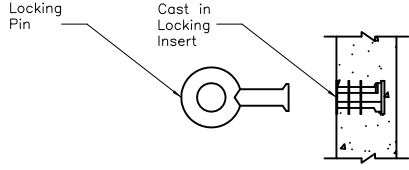
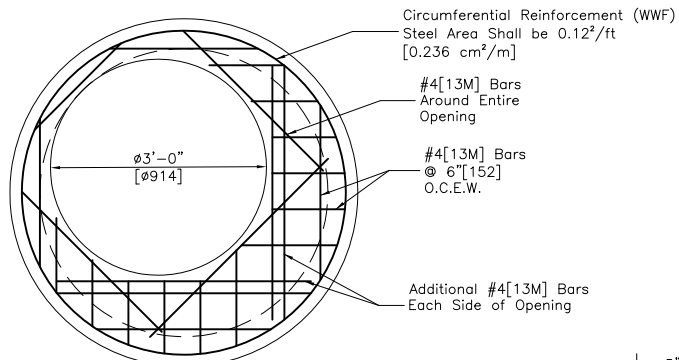
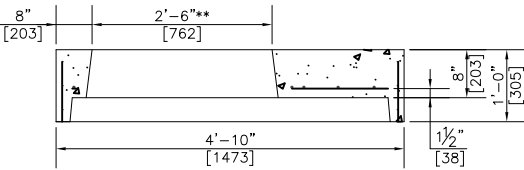
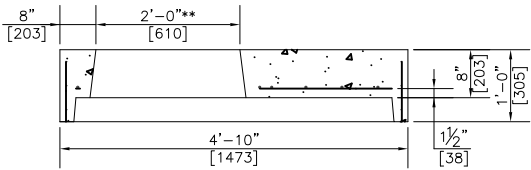
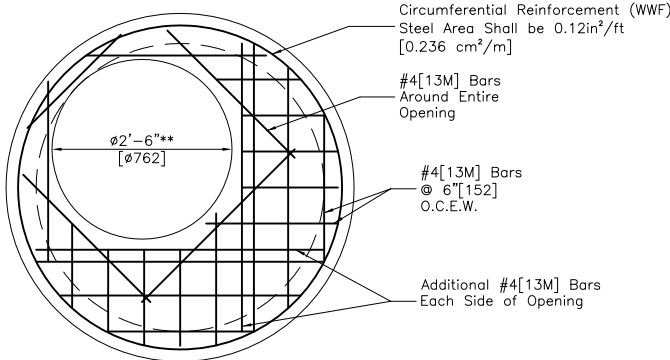
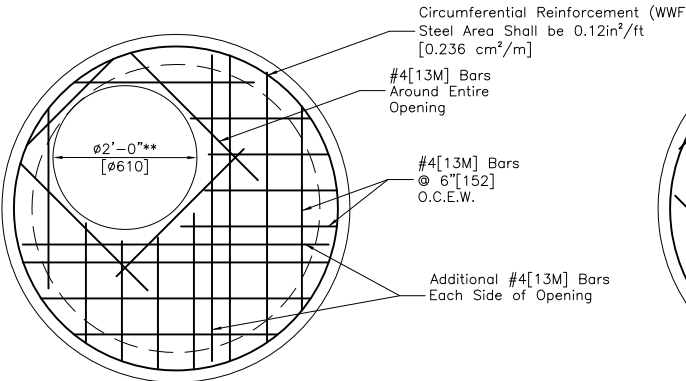

LIFTING DEVICE
DETAIL

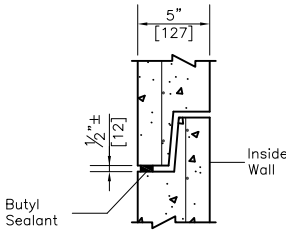
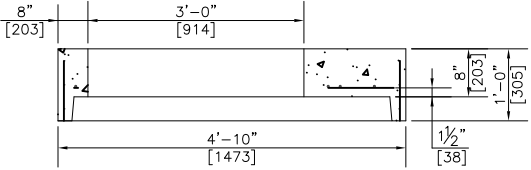

JOINT
DETAIL

PRODUCT WEIGHTS		
UNIT	HEIGHT (in/[mm])	WEIGHT (lbs/[kg])
EXT. BASE SECTION	24"[610]	3,250[1,476]
	36"[914]	4,050[1,839]
	48"[1219]	4,850[2,202]
RISERS	60"[1524]	5,650[2,566]
	12"[305]	800[363]
	24"[610]	1,600[727]
	36"[914]	2,400[1,090]
FLAT TOP SLAB	48"[1219]	3,200[1,453]
	24"[610] Open	1,650[749]
	30"[762] Open	1,500[681]
	36"[914] Open	1,250[568]

- NOTES:**
1. Minimum Concrete Compressive Strength = 4,000PSI[27,580kPa] shall be obtained prior to shipping.
 2. Product conforms to CTDOT Standard Specification Form 816 and CTDOT Standard Detail HW-507_04.
 3. Steel bar reinforcement shall conform to ASTM A615, Grade 60 with a minimum clear cover of 2"[50].
 4. Steel welded wire fabric (WWF) reinforcement shall conform to ASTM A185. Minimum circumferential steel area shall be 0.12 in²/ft[0.236 cm²/m] as per ASTM C478.
 5. All pipe openings to be closed by Contractor using materials conforming to CTDOT Standard Specification M.08.02.
 6. Butyl joint sealant shall conform to ASTM C990 and/or AASHTO M198.
 7. Knockouts for pipe openings shall be placed at the required location and height for project. There shall be a minimum 4"[102] distance between knockout and bottom or top of riser/transition. Steel reinforcement shall have minimum 2"[50] clear concrete cover. Maximum size of knockout may be govern by height of required riser/transition section.
 8. Flexible boot connections may be requested for pipe to manhole connections. Pipe size and type to be specified.
 9. Wall thickness will not change for structure depth over 10'-0"[3M] deep.
 10. An asphaltic coating can be applied to exterior surfaces of structure if required.

***=Nominal Dimension. Slight variation in dimensions may occur due to tapering for manufacturing purposes.