

Connecticut Precast Corp.

Manufacturers of Concrete Products

555 Fan Hill Road, Monroe, CT 06468
Telephone (203) 268-8688 Fax (203) 452-1007

www.ctprecast.com

Manholes 72"[1829] Diameter

PRECAST CONCRETE
W/STRAIGHT BASE SLAB
TRANSITION CONSTRUCTION

Manholes
CTDOT

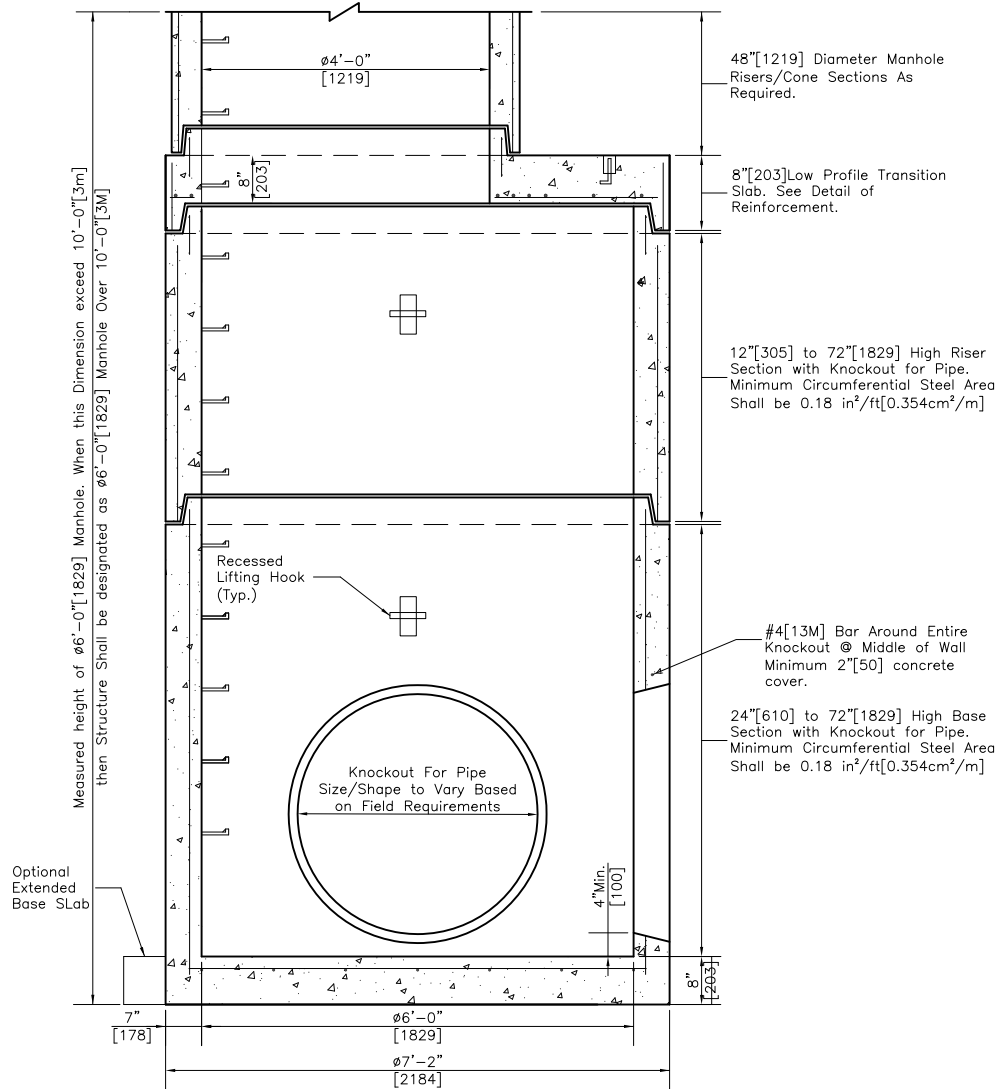

**=Nominal Dimension. Slight variation in dimensions may occur due to tapering for manufacturing purposes.

PRECAST CONCRETE 72"[1829] DIAMETER

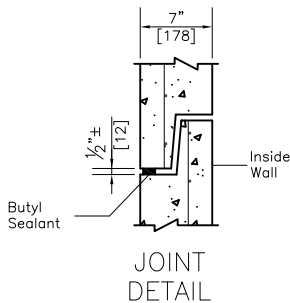
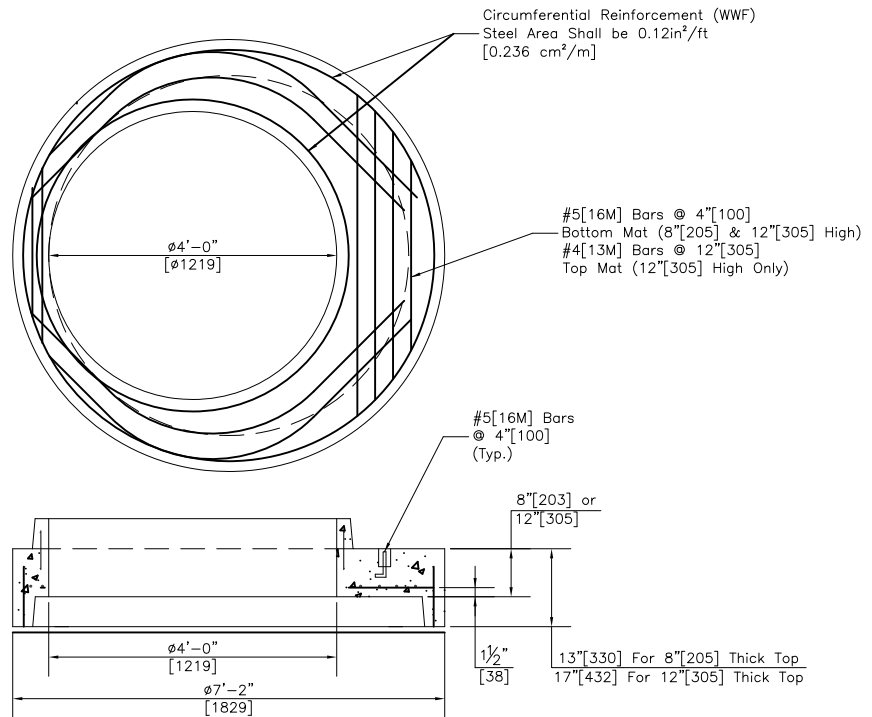

| PRODUCT WEIGHTS | | |
|-----------------|------------------|------------------|
| UNIT | HEIGHT (in/[mm]) | WEIGHT (lbs[kg]) |
| BASE SECTION | 24"[610] | 8,620[3,918] |
| | 36"[914] | 10,430[4,741] |
| | 48"[1219] | 12,240[5,564] |
| RISERS | 60"[1524] | 14,050[6,386] |
| | 72"[1828] | 15,860[7,209] |
| | 12"[305] | 1,810[823] |
| | 24"[610] | 3,620[1,645] |
| | 36"[914] | 5,430[2,468] |
| TRANSITION | 48"[1219] | 7,240[3,291] |
| | 60"[1524] | 9,050[4,113] |
| | 72"[1828] | 10,860[4,936] |
| | 8"[205] SLAB | 3,060[1,392] |
| | 12"[305] SLAB | 5,140[2,336] |

NOTES:

1. Minimum Concrete Compressive Strength = 4,000PSI[27,580kPa] shall be obtained prior to shipping.
2. Product conforms to ASTM C478 and AASHTO M199 Specifications.
3. Steel bar reinforcement shall conform to ASTM A615, Grade 60 with a minimum clear cover of 2"[50].
4. Steel welded wire fabric (WWF) reinforcement shall conform to ASTM A185. Minimum circumferential steel area shall be 0.18 in²/ft[0.354 cm²/m] as per ASTM C478.
5. All pipe openings to be closed by Contractor using materials conforming to CTDOT Standard Specification M.08.02.
6. Butyl joint sealant shall conform to ASTM C990 and/or AASHTO M198.
7. Knockouts for pipe openings shall be placed at the required location and height for project. There shall be a minimum 4"[102] distance between knockout and bottom or top of base/riser section. Steel reinforcement shall have minimum 2"[50] clear concrete cover. Maximum size of knockout may be govern by height of required base/riser section.
8. Flexible boot connections may be requested for pipe to manhole connections. Pipe size and type to be specified.
9. Wall thickness will not change for structure depth over 10'-0"[3M] deep.
10. An asphaltic coating can be applied to exterior surfaces of structure if required.

**=Nominal Dimension. Slight variation in dimensions may occur due to tapering for manufacturing purposes.