

# Connecticut Precast Corp.

Manufacturers of Concrete Products

555 Fan Hill Road, Monroe, CT 06468  
 Telephone (203) 268-8688 Fax (203) 452-1007 www.ctprecast.com

## Catch Basins

Catch Basin  
CTDOT

### CTDOT STANDARD PRECAST CONCRETE CATCH BASIN TOPS Type "C-L"

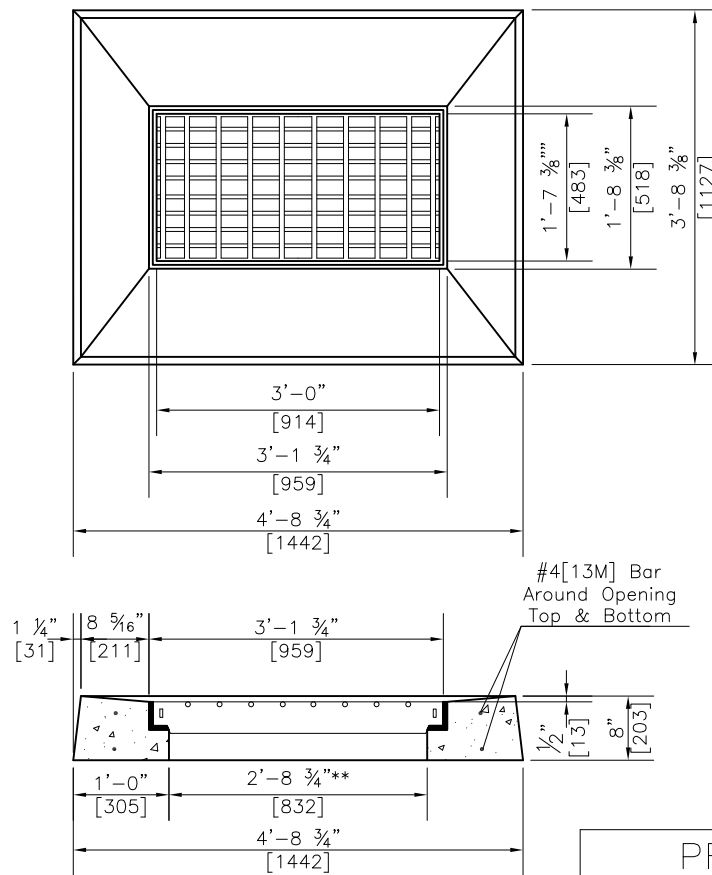

PRODUCT WEIGHTS		
UNIT	HEIGHT	WEIGHT
	(in[mm])	(lbs[kg])
"CL" TOP	8"[203]	1,100[499]

**NOTES:**

1. Minimum Concrete Compressive Strength = 4,000PSI[27,580kPa] shall be obtained prior to shipping.
2. Product conforms to CTDOT Standard Specification Form 816 and CTDOT Standard Detail HW-507-07.
3. Frame and Grate shall conform to CTDOT Standard Specifications Form 816 and CTDOT Standard Detail HW-507-08
4. Frame and Grate shall be either red painted or hot dipped galvanized. For CTDOT Frame and Grate shall be hot dipped galvanized only.
5. Type "A" grate shall be used on all roadways where bicycle traffic is allowed.  
 Type "B" grate shall be used on all limited access highways, ramps, and where bicycle traffic is not allowed.
5. Steel reinforcement shall conform to ASTM A615, Grade 60 and have a minimum clear cover of 2"[50].
6. Approximate Weights, lbs[kg] = 1,100[499]:

\*\*=Nominal Dimension. Slight variation in dimensions may occur due to tapering for manufacturing purposes.