

Weight Each: 46 lbs.

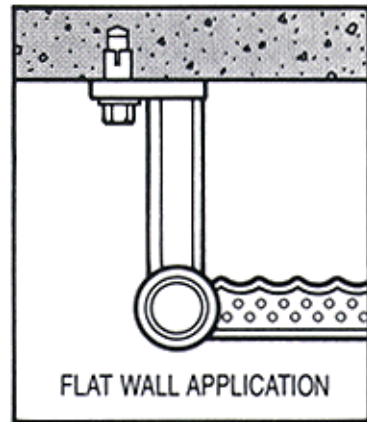
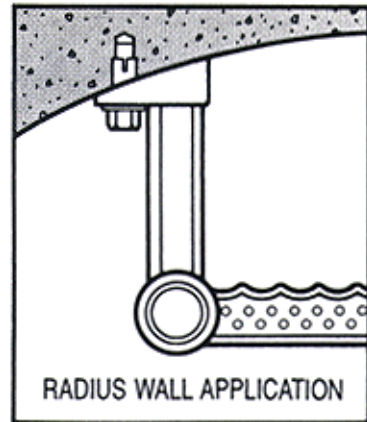
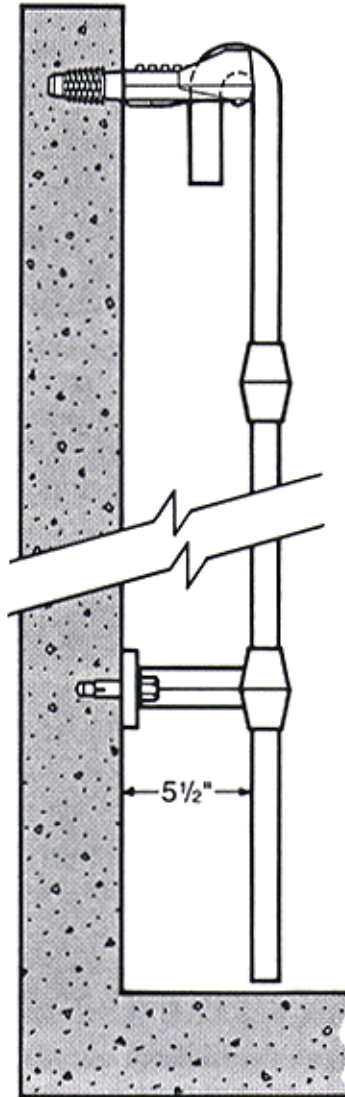

Ladders to be fastened to wall with 1/2" x 2 3/4" stud anchors

Polypropylene conforms to ASTM D-4101. Ladders meet all ASTM C-497 load requirements.

12 STEP POLY LADDER

LANE INTERNATIONAL CORPORATION

PO Box 925
10758 SW Manhasset Dr.
Tualatin, OR 97062

503-692-9860
800-666-0076
Fax 503-692-9863
www.laneinternational.com

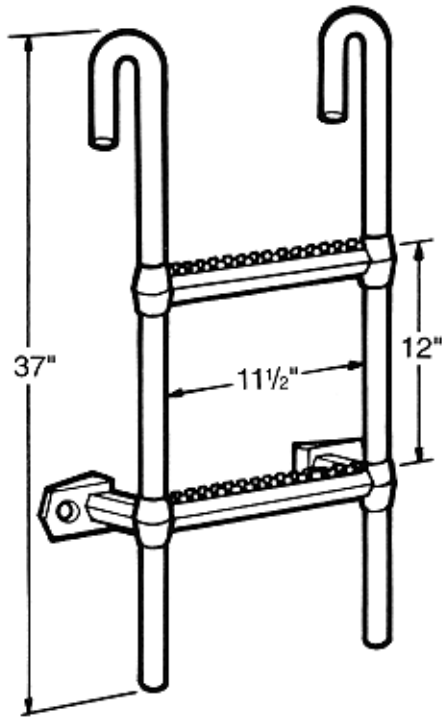

Weight Each: 10 lbs.

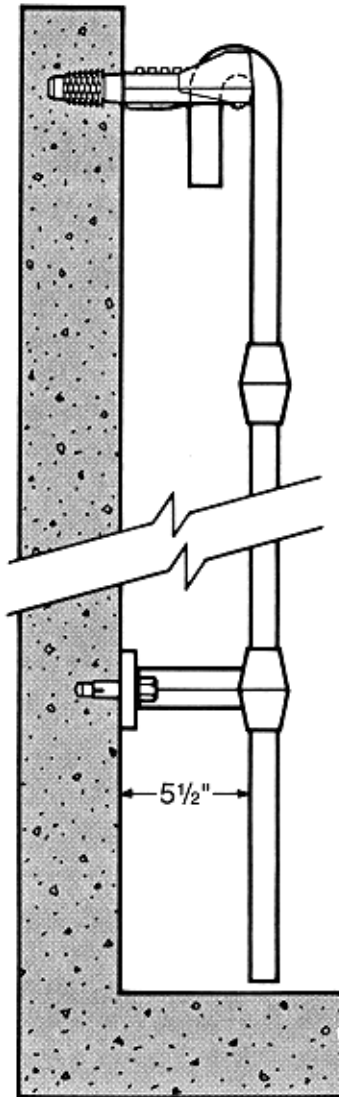

WALL FASTENING

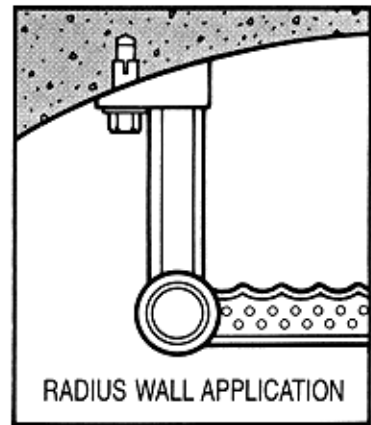

RADIUS WALL APPLICATION

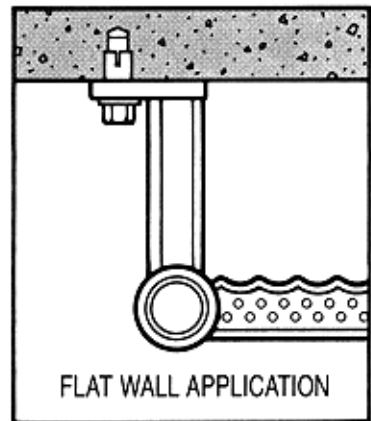

FLAT WALL APPLICATION

Ladders to be fastened to wall with 1/2" x 2 3/4" stud anchors

Polypropylene conforms to ASTM D-4101. Ladders meet all ASTM C-497 load requirements.

2 STEP POLY LADDER

LANE INTERNATIONAL CORPORATION

PO Box 925
10758 SW Manhasset Dr.
Tualatin, OR 97062

503-692-9860
800-666-0076
Fax 503-692-9863
www.laneinternational.com